

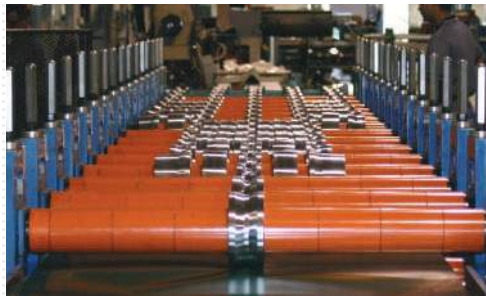

3. INNOVATIVE PROCESS

One of the greatest assets of Everlast, and what sets us apart is the **Evercure® Process**. This process includes the revolutionary CECI® enhancement that not only seals the metal's cut edge, but also protects it from both natural and commercial corrosive elements. **Everlast's panels are stronger, more durable and less likely to crack over time.** The Evercure® Process is state-of-the-art and we are confident it will continue to set the standard for quality metal building components.



HEAT FORMING™

Everlast pioneered the Heat Forming process nearly 20 years ago and the technology remains unmatched. It is a crucial step in making the most corrosion resistant panel possible. Before the finished panel is formed, it is heated with infrared energy causing the steel's coatings to become more flexible. This virtually eliminates crazing and microfracturing at the bend lines, which are leading causes of premature rusting.

ADVANCED TOOLING

Advanced State-of-the-Art Tooling is another area of excellence in Everlast Roofing's roll formed products. Using additional stands places less stress on the formed radius of our panel providing for the most consistent panel profile on the market.



CECI®

To combat edge rust, Everlast introduced Cut-Edge-Corrosion-Inhibitor, known as CECI. Applied after the panel is formed, CECI provides an invisible layer of protection, so end-users will see virtually no sign of CECI as it quietly protects and effectively decreases corrosion rates, as proven through industry research.

4. PACKAGING & DELIVERY

All of our products are packaged and banded together to ensure a **high level of quality control during shipment**. All of our trim and accessories are packaged to be shipped or picked-up. Our distribution services guarantee **on-time delivery and reliable transportation**. We proudly service clientele with a fleet of company-owned trucks and company drivers.



MID-ATLANTIC
10 Enterprise Court
Lebanon, PA 17042

CENTRAL
161 Grand Valley Ave.
Orwell, OH 44076

MIDWEST
7180 N 050 E
Howe, IN 46746

NEW ENGLAND
24 JR Mains Drive
Bridgton, ME 04009

EVERLASTROOFING.COM
TOLL FREE: 888.339.0059

OMNISERIES

TESTED. TRUSTED. TOUGHER THAN EVER...



888.339.0059

EVERLASTROOFING.COM

WHAT SETS US APART?

IT'S AS SIMPLE AS 1,2,3...

1. SUPERIOR BARRIER PROTECTION

AZM® with Activate Technology sets a new industry benchmark for corrosion control with the addition of magnesium into the aluminum-zinc coating. Magnesium forms a chemical reaction with aluminum and activates sacrificial characteristics not previously present. The result is a product that provides self-sealing protection.

2. EXCLUSIVE PAINT SYSTEM

COLORBOND® is the direct result of extensive research and development to formulate a superior paint system against severe weather conditions and UV Penetration. Tested in the harshest environments throughout the world, **COLORBOND®** outlasts and outperforms all other paint systems in the market.

3. INNOVATIVE PROCESS

Even the best raw materials on earth can be ruined by the wrong roll forming technique. That's why Everlast pioneered the **Evercure™ Process**. We begin by heating our panels to increase flexibility. Then, our rollformer utilizes more passes to form the panel more gradually. Finally, we seal the cut edge with our **CECI** technology, and deliver it in the industry's sturdiest packaging.

4. PACKAGING & DELIVERY

All of our products are packaged and banded together to ensure a **high level of quality control during shipment**. All of our trim and accessories are packaged to be **shipped or picked-up**. Our distribution services guarantees **on-time delivery and reliable transportation**.

THE NEXT GENERATION

Everlast Roofing is proud to be an innovator in our field. Our promise to our customers is to continue to push boundaries to produce superior performing products. It is this promise that has led to the introduction of **AZM® with Activate Technology** and **COLORBOND®** with the release of our next generation product. Backed with a 20-year proven record of outperforming all others in both accelerated laboratory and real world harsh environment exposure tests, **Everlast Roofing is the only company in North America to offer this technology.**



1. TRUE 27 GAUGE STEEL

At its core, the **OMNI series is built on true 27 gauge steel**, that's measured *before* paint, not after. This thicker steel is the fundamental design difference of the Everlast II OMNI panel, boasting **long-term strength, enabling higher snow and wind yields, and unprecedented hail resistance**. Additional benefits include improved job-site durability, and the reduction of oil canning, ghosting and purlin show through.

SUPERIOR BARRIER PROTECTION

The **OMNI series includes the latest in corrosion resistance with the Next Generation AZM® coating with Activate Technology, which provides for the best corrosion resistance in the industry.** This first-of-its-kind metallic coating introduces magnesium into the aluminum-zinc alloy coating, which improves galvanic protection by activating the aluminum.

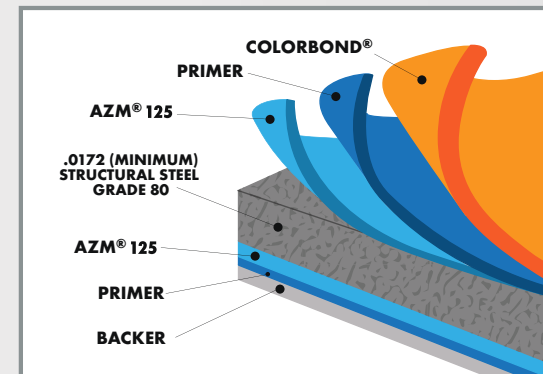

AZM®: MORE SUPERIOR CORROSION RESISTANCE



G100



AZ50®



AZM® 125

AZM® Steel vs Galvanized Steel

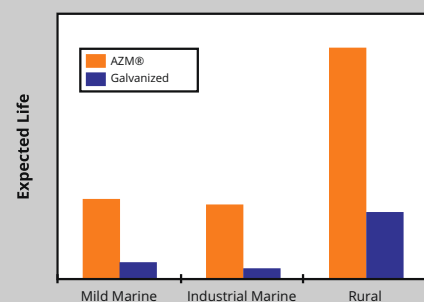

AZM® Steel vs Galvalume Steel

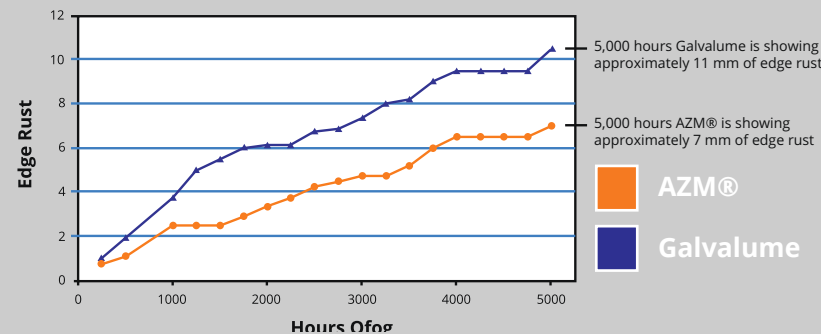

2. EXCLUSIVE PAINT SYSTEM

COLORBOND® has been tested in some of the harshest regions of the world, where corrosive environments and high solar intensity take their toll on painted products. Even with over 50 years of proven excellent durability in locations across the globe, Blue Scope Steel and Everlast Roofing continue to test and evaluate **COLORBOND®** for resistance to corrosion, dirt retention, chalking, color fade and gloss retention.

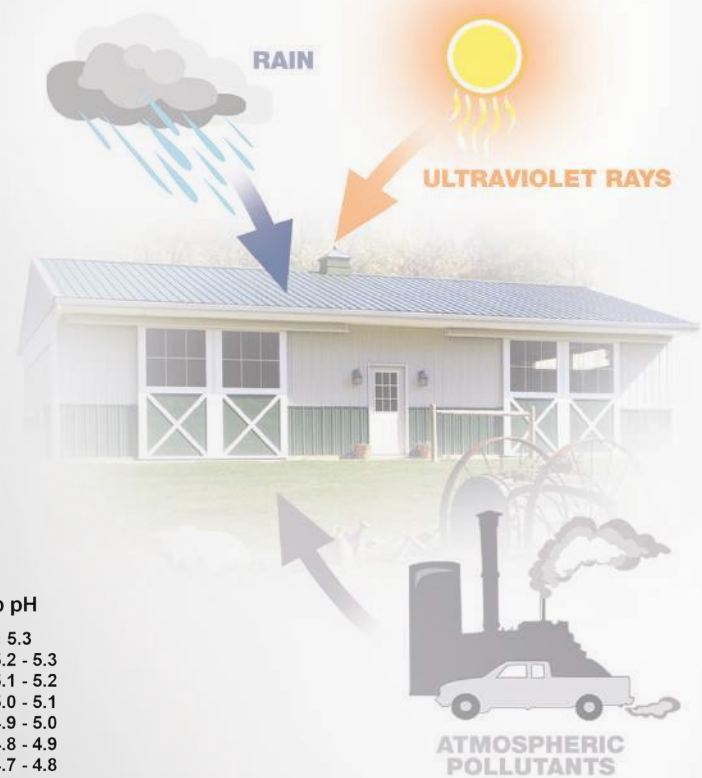
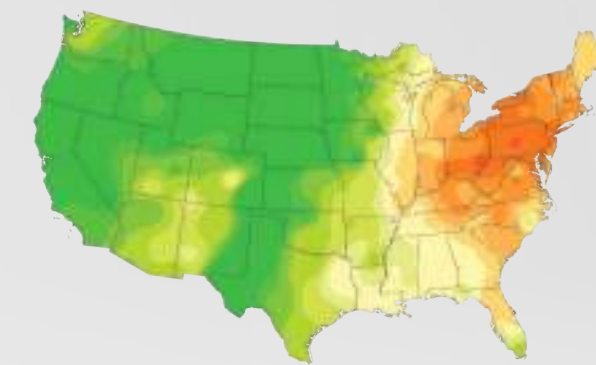

Colorbond® COMPETITOR



Colorbond® COMPETITOR

TESTING IN REAL CONDITIONS

Panels shown above are actual samples that were exposed to real-life outdoor conditions on the same building. **COLORBOND®** is trending to surpass the competitor current and previous SMP Technology.

CHALK RESISTANCE

A white powdery residue or appearance on the surface of the panel is evidence of chalking. Chalking is a direct result of a breakdown in the resin that is, most often, the result of environmental weathering.

COLORBOND®	COMPETITOR	
ORIGINAL	ORIGINAL	ORIGINAL
CHALK RATE OVER TIME	CHALK RATE OVER TIME	CHALK RATE OVER TIME
NEXT GENERATION	NEW SMP TECHNOLOGY	PREVIOUS SMP TECHNOLOGY

FADE RESISTANCE

A gradual change in the panel's paint color or gloss is known as fading. Fading occurs when there is a breakdown in the pigment caused by direct panel exposure to the sun's UV rays.

COLORBOND®	COMPETITOR	
ORIGINAL	ORIGINAL	ORIGINAL
FADE RATE OVER TIME	FADE RATE OVER TIME	FADE RATE OVER TIME
NEXT GENERATION	NEW SMP TECHNOLOGY	PREVIOUS SMP TECHNOLOGY